

1 Screen Front
1:40

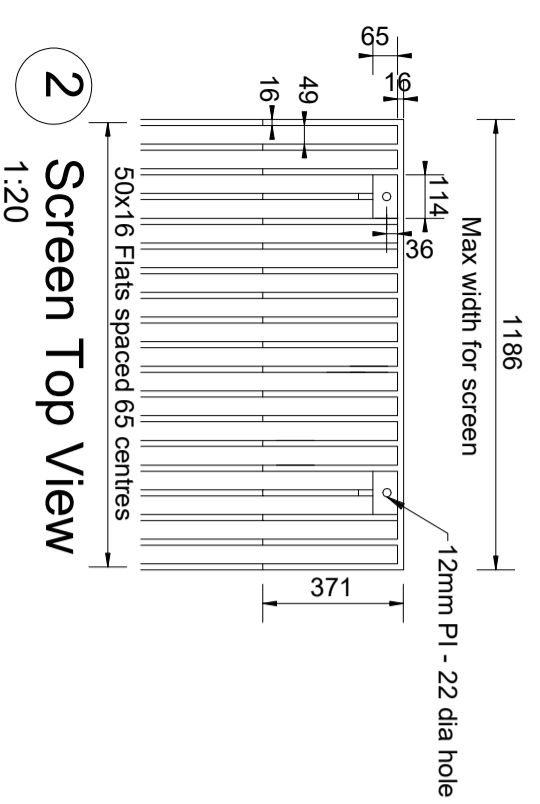

2 Screen Top View
1:20

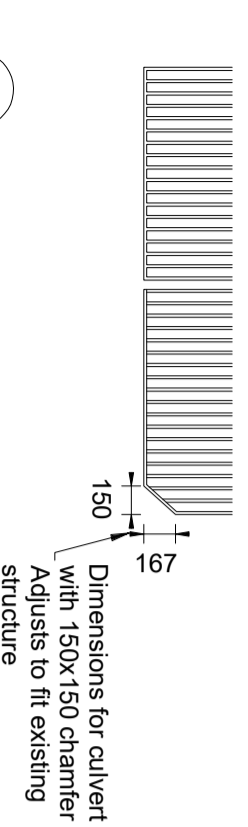

3 Screen Bottom
1:40

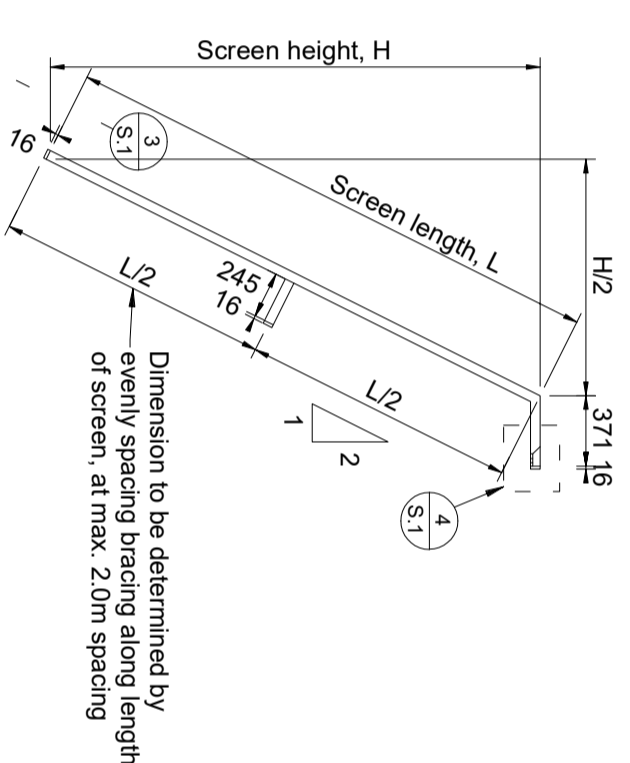

5 Screen Elevation
1:40

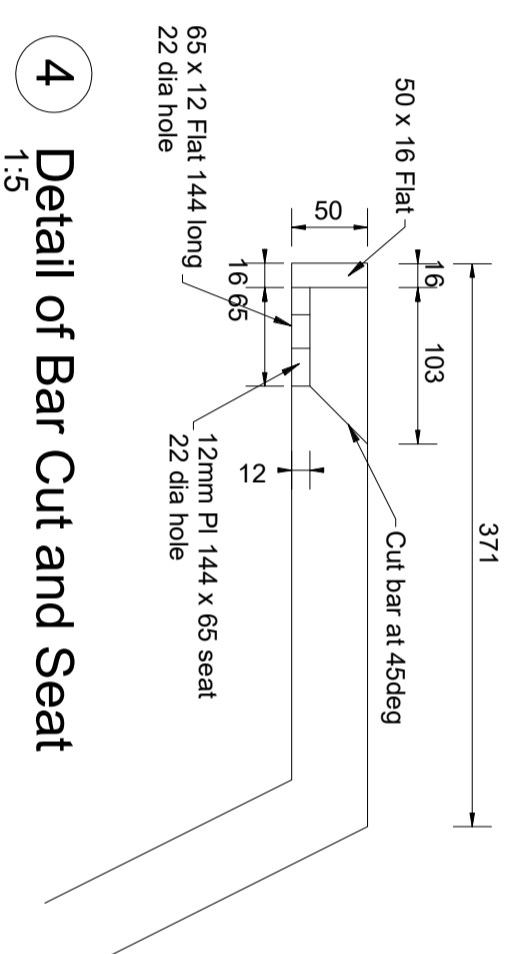

4 Detail of Bar Cut and Seat
1:5

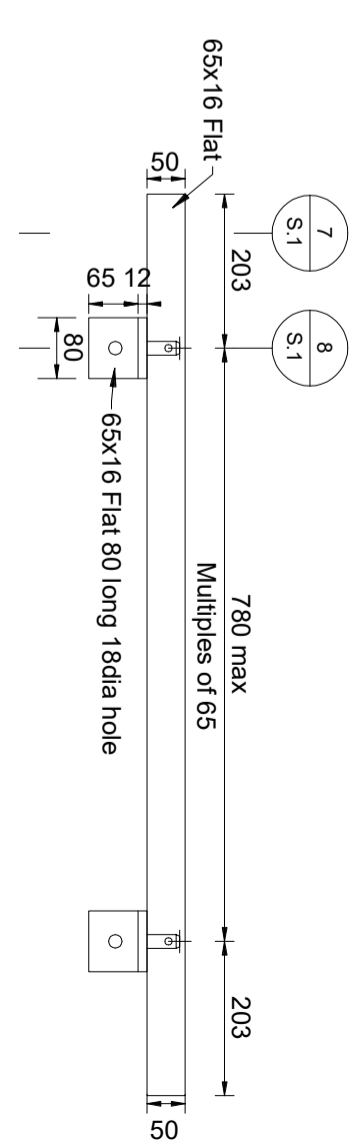

6 Screen Hook Front
1:10

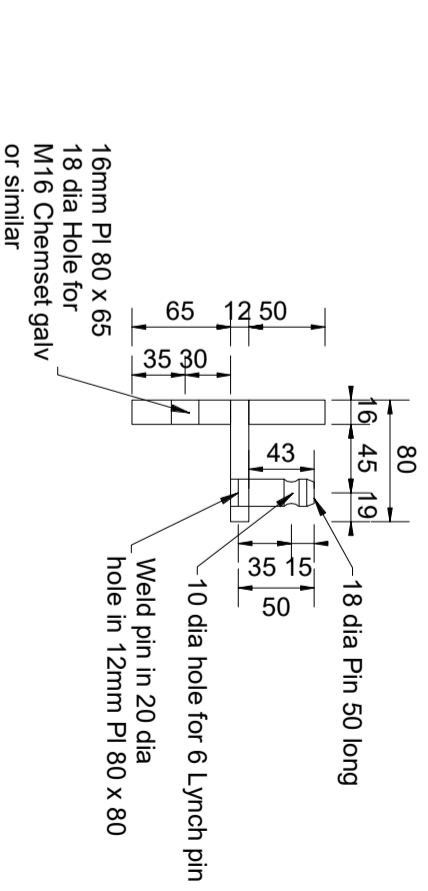

7 Screen Hook Detail
1:5

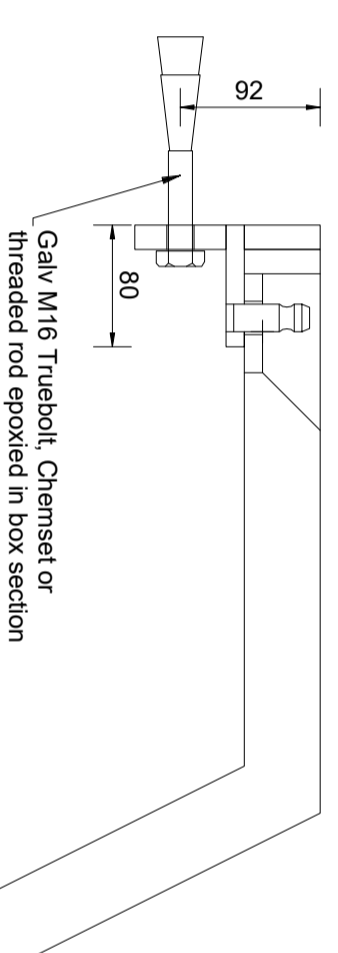

8 Screen Fit on Hook
1:5

- NOTES:**
1. Read notes on all sheets together with specifications and notify engineer immediately of any discrepancies.
 2. Structural steel grade 300.
 3. All welded connections shall be of GP grade metal arc and comply with AS1554:Part 1.
 4. Butt welds shall be full penetration, using backing plates as required.
 5. All fillet welds to be as shown, else 6mm or thickness of element if smaller. Welds are all-round to avoid moisture trap.
 6. All structural steel elements shall be HDG500 hot dipped galvanised to AS/NZS 4680.
 7. All bolts and threaded rods hot-dip galvanised.

0	Construction Issue	A Morphet 15/08/19
Rev	Description	Approved Date



Standard Drawings

Weed Screen

Date:	15 August 2019	Drawn:	A McCaughan
Drawing Number:	WRC-1690	Checked:	M Farrell
Scale:	As indicated	REV	0