

1 Plan

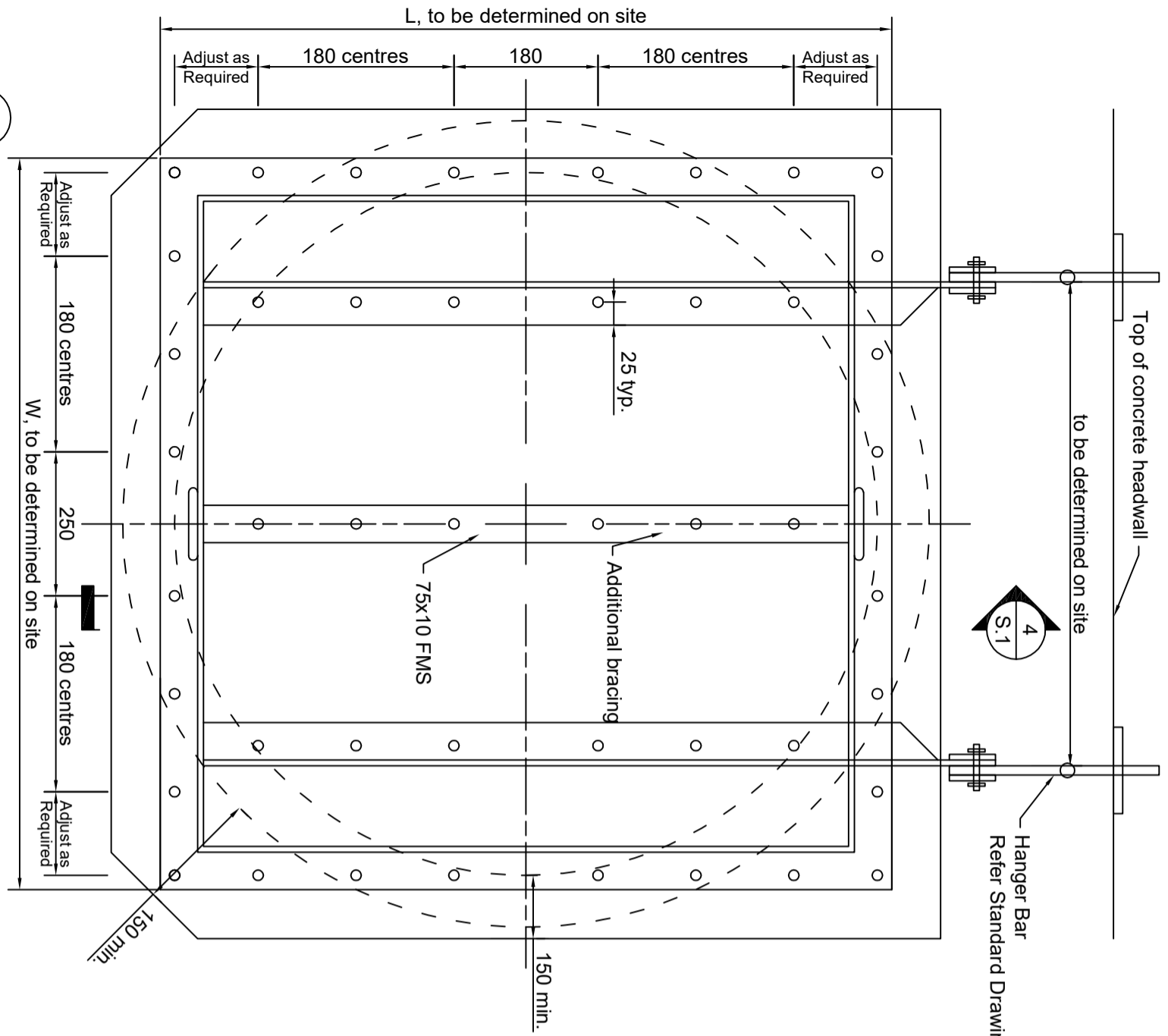

3 Elevation of Fabricated Steel Frame

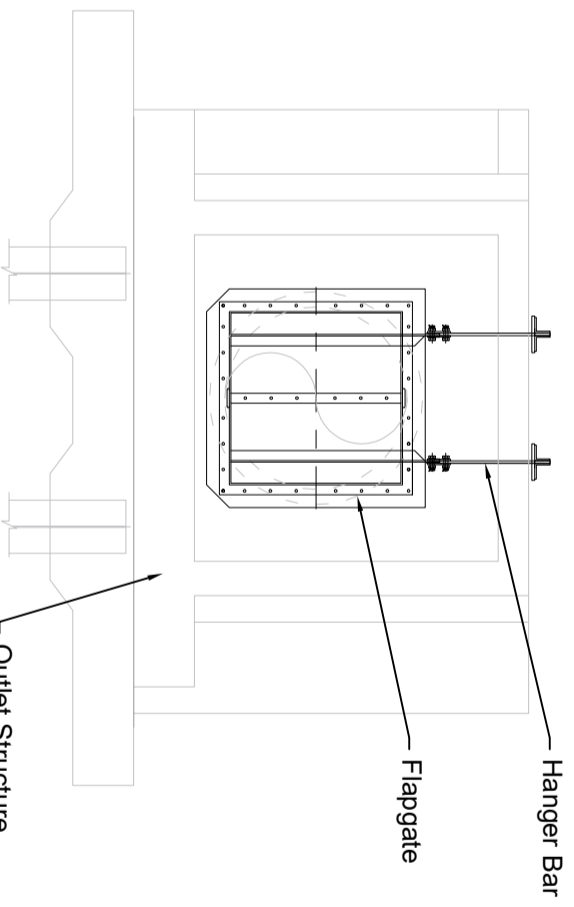

2 Elevation

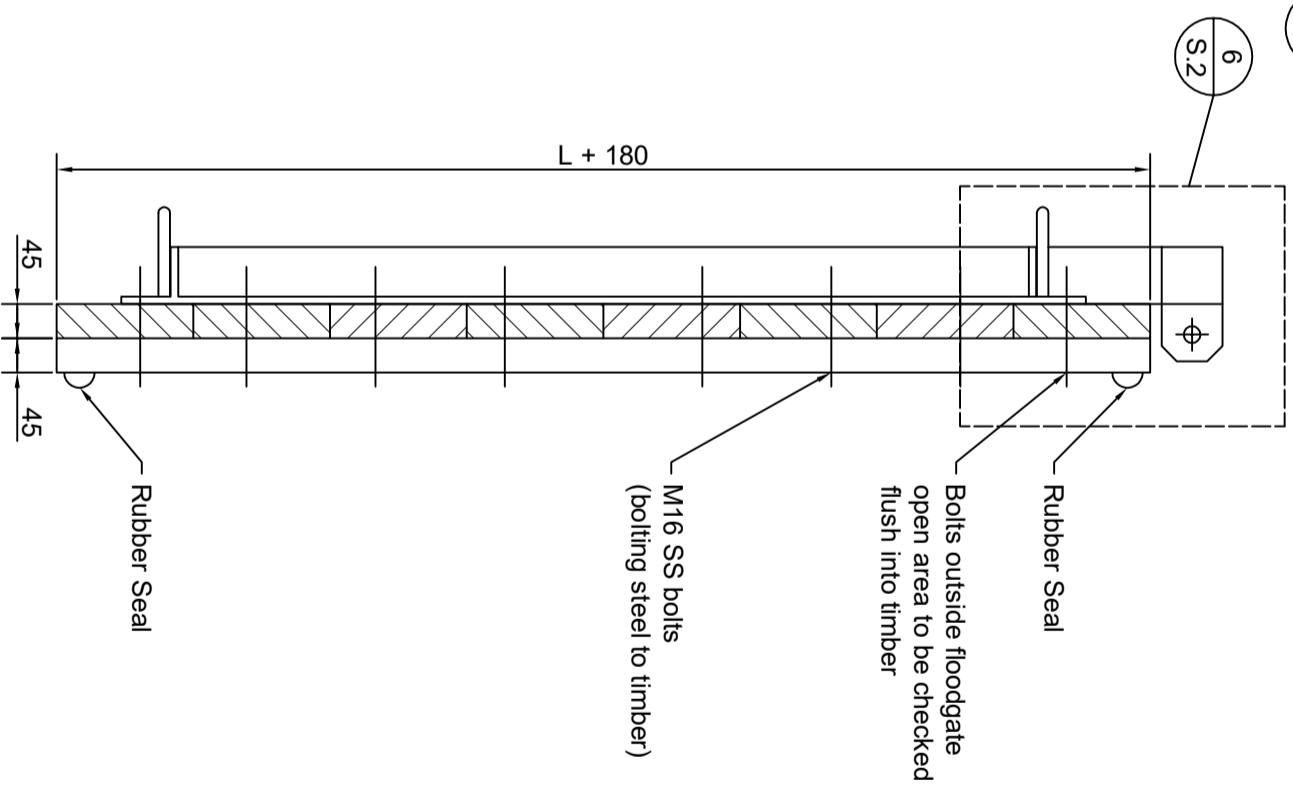

4 Section

NOTES:

1. Read notes on all sheets together with specifications and notify engineer of any discrepancies.
2. All dimensions in millimeters unless specified otherwise.
3. Contractor to confirm dimensions prior to fabrication.
4. A suitable electrode with a minimum tensile strength of 410MPa is to be used for all welds. Sealing welds are to be made on all unwelded seams.
5. Remove all burrs, sharp edges, weld slag and spatter when fabrication is complete and prior to galvanising.
6. All fabricated sheet components are to be hot-dip galvanised.
7. All nuts, bolts and washers are to be 304 SS.
8. The flapgate is designed for a maximum head of 4.6m.
9. The hanger bar length is to be verified after completion of headwall construction.
10. Flapgate is suitable for outlet diameter <1m and head <4m.
11. Component Specifications:
12. **Winch:** Alliquip BHW-2600 S/S with auto brake  
**Chain:** 6mm regular link galvanised  
**Pulley:** S/S open pulley with pin  
**Rubber Seal:** Skeller floodgate rubber seal Code PKA069

0	Construction Issue	A Morphet	29/1/19
Rev	Description	Approved	Date



**Standard Drawings**  
**Flapgate**  
**Small Diameter (<1.0m)**  
**Small Head (<4m)**

Date:	29 November 2019	Drawn:	A McCaughan
Drawing Number:	WRC-1698	Checked:	M Farrell
Scale:	As indicated	REV	0